

SurroundVideo® Omni G2

Installation Manual

Models:

12 Megapixel

- AV12275DN-NL
- AV12275DN-28
- AV12275DN-08
- AV12276DN-NL
- AV12276DN-28
- AV12276DN-08

20 Megapixel

- AV20275DN-NL
- AV20275DN-28
- AV20275DN-08

Contents

| | |
|-------------------------------------------------|----|
| Package Contents..... | 3 |
| In-ceiling Mount..... | 10 |
| Pendant Mount..... | 12 |
| Surface Mount..... | 14 |
| Wall Mount..... | 17 |
| Pole Mount | 18 |
| Corner Mount | 20 |
| Electrical Box Adapter | 22 |
| Setting up the Cameras..... | 23 |
| Aligning the Cameras | 25 |
| Adjusting the Pan, Tilt and Focus..... | 26 |
| Changing the Lens..... | 27 |
| Auxiliary I/O Functions..... | 28 |
| OUTPUT Relay Control and Function..... | 29 |
| INPUT Alarm Control and Detection | 30 |
| Camera Discovery, Setup, and Configuration..... | 34 |
| Network Protocols..... | 34 |
| General Remote Focus | 35 |
| AV IP Utility Focus Tab | 37 |
| Troubleshooting | 38 |
| SurroundVideo Omni Mounting Template | 39 |
| Support | 40 |



CAUTION!

1. Do not attempt to service a damaged unit yourself. Refer all servicing to qualified service personnel.
2. Wiring methods shall be in accordance with the National Electrical Code/NFPA 70/ANSI, and with all local codes and authorities having jurisdiction. Wiring should be UL Listed and/or Recognized wire suitable for the application.
3. Always use hardware e.g. screws, anchors, bolts, locking nuts etc. which are compatible with mounting surface and of sufficient length and construction to insure a secure mount.

Package Contents

This equipment should be unpacked and handled with care. The original packaging is the safest container in which to transport the unit and can be used if returning the unit for service. The packaging contains:

- One (1) Arecont Vision Camera
- One (1) mounting template
- Three (3) Mounting Wood Screws (#6x1" for wood or sheet metal)
- Three (3) Mounting Dry Wall Anchors
- One (1) Ceiling Gasket
- One (1) Aux Power Cord
- One (1) Network Patch Cable
- One (1) Security L-key
- One (1) Tether plate
- One (1) CD with Manual and Software

Warranty Information

Global (3 Year) Limited Warranty

ARECONT VISION warrants to Purchaser (and only Purchaser) (the “Limited Warranty”), that: (a) each Product shall be free from material defects in material and workmanship for a period of **thirty-six (36) months** from the date of shipment (the “Warranty Period”); (b) during the Warranty Period, the Products will materially conform with the specification in the applicable documentation; (c) all licensed programs accompanying the Product (the “Licensed Programs”) will materially conform with applicable specifications. Notwithstanding the preceding provisions, ARECONT VISION shall have no obligation or responsibility with respect to any Product that (i) has been modified or altered without ARECONT VISION’s written authorization; (ii) has not been used in accordance with applicable documentation; (iii) has been subjected to unusual stress, neglect, misuse, abuse, improper storage, testing or connection; or unauthorized repair; or (iv) is no longer covered under the Warranty Period. ARECONT VISION MAKE NO WARRANTIES OR CONDITIONS, EXPRESS, IMPLIED, STATUTORY OR OTHERWISE, OTHER THAN THE EXPRESS LIMITED WARRANTIES MADE BY ARECONT VISION ABOVE, AND ARECONT VISION HEREBY SPECIFICALLY DISCLAIMS ALL OTHER EXPRESS, STATUTORY AND IMPLIED WARRANTIES AND CONDITIONS, INCLUDING THE IMPLIED WARRANTIES OF MERCHANTABILITY, FITNESS FOR A PARTICULAR PURPOSE, NON-INFRINGEMENT AND THE IMPLIED CONDITION OF SATISFACTORY QUALITY. ALL LICENSED PROGRAMS ARE LICENSED ON AN “AS IS” BASIS WITHOUT WARRANTY. ARECONT VISION DOES NOT WARRANT THAT (I) THE OPERATION OF THE PRODUCTS OR PARTS WILL BE UNINTERRUPTED OR ERROR FREE; (II) THE PRODUCTS OR PARTS AND DOCUMENTATION WILL MEET THE END USERS’ REQUIREMENTS; (III) THE PRODUCTS OR PARTS WILL OPERATE IN COMBINATIONS AND CONFIGURATIONS SELECTED BY THE END USER; OTHER THAN COMBINATIONS AND CONFIGURATIONS WITH PARTS OR OTHER PRODUCTS AUTHORIZED BY ARECONT VISION OR (IV) THAT ALL LICENSED PROGRAM ERRORS WILL BE CORRECTED.

For RMA and Advance Replacement information visit <http://www.arecontvision.com>

Camera Overview

The SurroundVideo® Omni G2, next generation multi-sensor, multi-megapixel dome camera pushes the ease of installation even further providing users with four (4) remote focus lens options on a unique 360° magnetic track encompassed in a single indoor/outdoor, impact-resistant housing. The customization of this camera is unparalleled offering a range of interchangeable lens options for each individual sensor including 2.1, 2.8, 4, 6, 8, 12 and 16mm options.

For added flexibility, users can place the four individual three-axis lens gimbals independently in nearly any configuration on the track for applications such as hallway intersections or the corner of a building for a 270° view. The three-axis lens adjustment provides users with more camera placement options, allowing the cameras to be easily mounted on a wall or ceiling so they can pan, tilt, and rotate the lens in a variety of directions for a precise field of view.

The SurroundVideo® Omni G2 multi-megapixel camera series features a choice of 12- or 20-megapixel resolution options. These cameras provide an all-in-one solution for capturing wide area video surveillance while maximizing the field-of-view and reducing the total number of cameras required saving installers time and end users money.

Regardless of time-of-day, this camera is ideal for applications with challenging lighting conditions. The series combines a day/night mechanical IR cut filter for the highest image quality at any time of day. For applications with bright or over saturated lighting conditions, optional wide dynamic range delivers up to 100dB at full resolution and is available on select 12MP models. For applications with poor low lighting conditions, Binning Mode increases the camera's low light performance by combining pixels so that more light can be collected.

Once mounted, the operator can quickly focus and position the camera remotely, eliminating the need to adjust the camera on-site. No more hassle individually installing multiple cameras to cover a wide area, manually focusing lenses, or risk missing critical information.

SurroundVideo® Omni G2 is designed for demanding environments. Subjected and certified to rigorous dust and water tests, the IP66 rating, and its extended operating temperature range make it ideal for outdoor applications. The IK-10 rated, rugged dome housing is perfect for deterring vandals since it can withstand the equivalent of 55 kg (120 lbs) of force.

The camera offers advanced streaming capabilities and is designed on an efficient H.264 encoding platform capable of delivering high quality video without straining the network. Power can be supplied via a single Power-over-Ethernet compliant network cable or with power from a 12-48V DC/24V AC power supply.

The camera's interface allows for an intuitive, fast, and easy configuration; while the Free AV IP Utility tool allows users to quickly configure multiple cameras at one time. The SurroundVideo® Omni G2 is PSIA (Physical Security Interoperability Alliance) compliant, providing interoperability between network video products regardless of manufacturer.

Installation

1. Determine a secure location to mount the camera.
2. Use the supplied security L-key, to loosen the four (4) screws securing the dome cover.

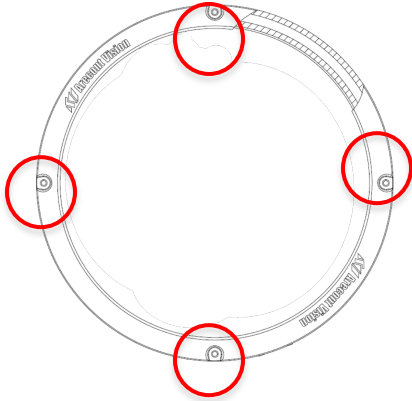

3. Remove the dome cover and protective foam. Do not remove screws from the dome cover.

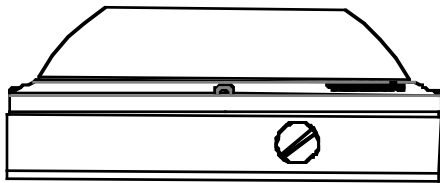

The SurroundVideo® Omni G2 camera has been designed to provide installers with flexible mounting options such as ceilings, walls, poles or corners.

NOTE: When mounting the camera outdoors or in a wet environment, use of supplied rubber gasket is recommended. Ensure the three holes on the top of the housing are aligned with the gasket and it is properly seated flush with the camera housing.

Ensure you have the proper compatible mounting parts prior to starting your installation:

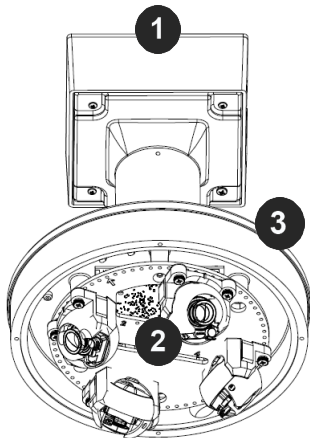

Pendant mount

| Reference # | Pendant Mount Components Required |
|-------------|------------------------------------------------------|
| 1 | Pendant mount (AV-PMJB) with integrated junction box |
| 2 | SurroundVideo® Omni G2 camera |
| 3 | SO-CAP mounting cap |

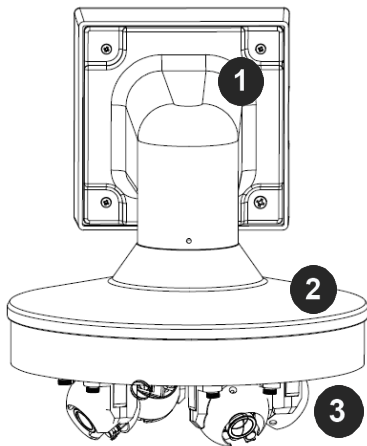

Wall mount

| Reference # | Wall Mount Components Required |
|-------------|---------------------------------------------------|
| 1 | Wall mount (AV-WMJB) with integrated junction box |
| 2 | SurroundVideo® Omni G2 camera |
| 3 | SO-CAP mounting cap |

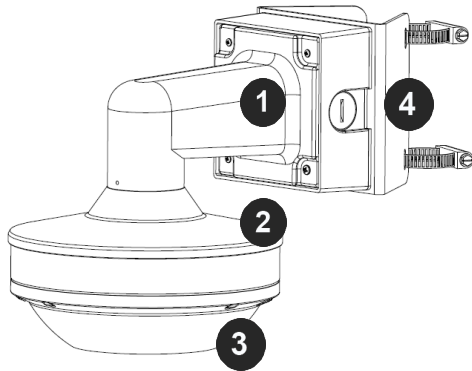

Pole mount

| Reference # | Mount Type | Pole Mount Components Required |
|-------------|------------|--------------------------------|
| 1 | Pole mount | AV-WMJB wall mount |
| 2 | | SO-CAP mount cap |
| 3 | | SurroundVideo® Omni G2 camera |
| 4 | | AV-PMA pole mount adapter |

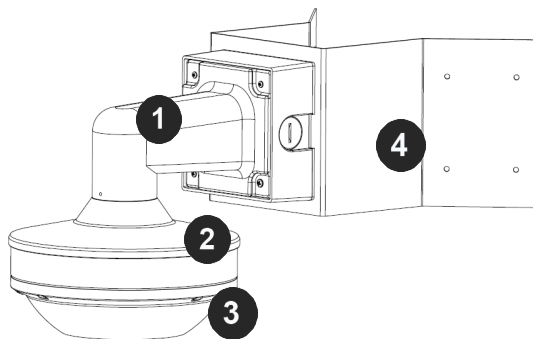

Corner mount

| Reference # | Mount Type | Corner Mount Components Required |
|-------------|--------------|----------------------------------|
| 1 | Corner mount | AV-WMJB wall mount |
| 2 | | SO-CAP mount cap |
| 3 | | SurroundVideo® Omni G2 camera |
| 4 | | AV-CRMA corner mount adapter |

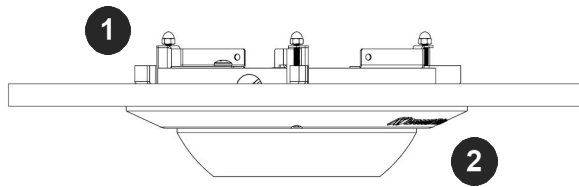

| Reference # | Mount Type | In-ceiling Mount Components Required |
|-------------|------------------|--------------------------------------|
| 1 | In-ceiling mount | SO-FMA in-ceiling adapter |
| 2 | | SurroundVideo® Omni G2 camera |

NOTE: It is recommended to conduct periodic inspections of the installation. Rust on the metal parts or screws may result in damage to the camera.

4. Use the Arecont Vision software AV IP Utility located on the CD or available for download at our website (www.arecontvision.com) for camera discovery and setup (see Instruction Manual located on the CD or available on our website).

In-ceiling Mount

To properly flush mount the SurroundVideo® Omni G2 to a drop ceiling or similar surface, a flush mount adapter kit (SO-FMA) is required (sold separately).

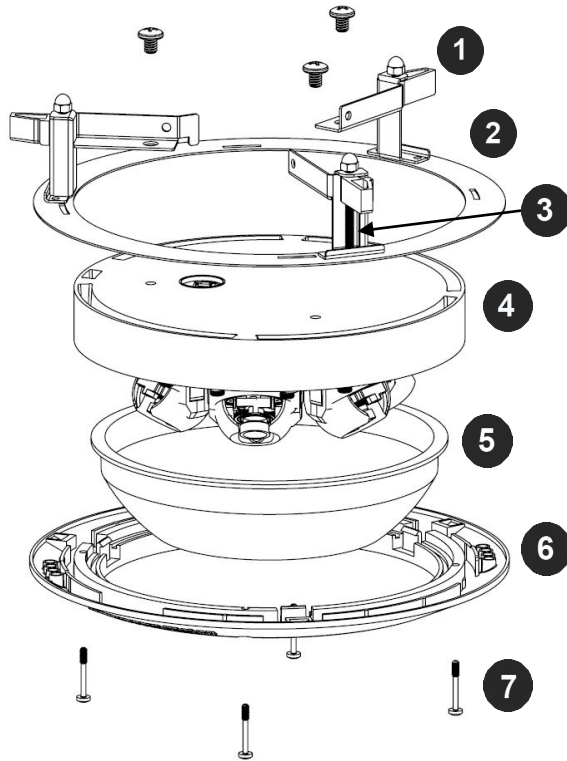

| Reference # | Description |
|-------------|-------------------------------------|
| 1 | SO-FMA flange plate support arm |
| 2 | SO-FMA flush mount bracket assembly |
| 3 | Lever screw |
| 4 | SurroundVideo Omni G2 camera |
| 5 | Bubble (without gasket) |
| 6 | SO-FMA trim ring |
| 7 | Trim ring screws |

1. Cut a 9" diameter hole in the ceiling using the template provided.

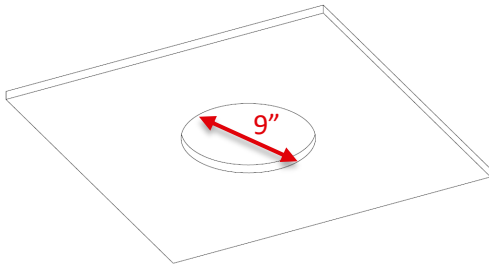

2. Remove existing Dome cover from Omni G2 camera and remove gasket from Bubble.
3. Attach Flush mount bracket assembly to Omni G2 camera as shown and fasten a safety cable to one of the 3 holes in the bracket assembly. (Cable not supplied.)

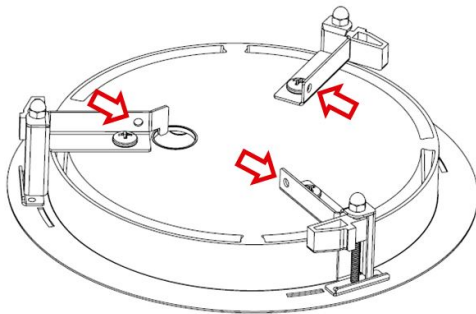

4. Insert housing assembly into ceiling hole and tighten the lever screws until the flush mount is snugly installed. The "Support Arm" will ride down the screw to compress the mounting surface. NOTE: Do not over-torque the lever screws.

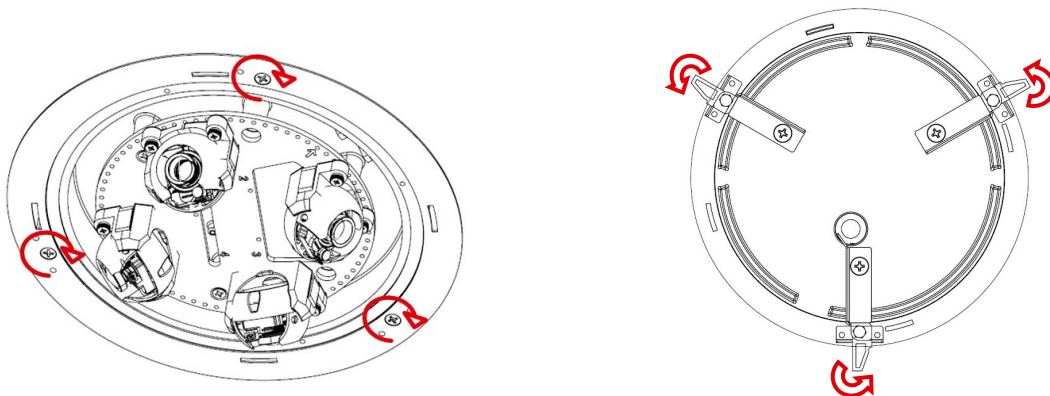

5. Snap bubble (without gasket) into flush mount trim ring and attach the trim ring to the flush mount adapter by rotating until it magnetically snaps in place then tighten the trim ring screws.

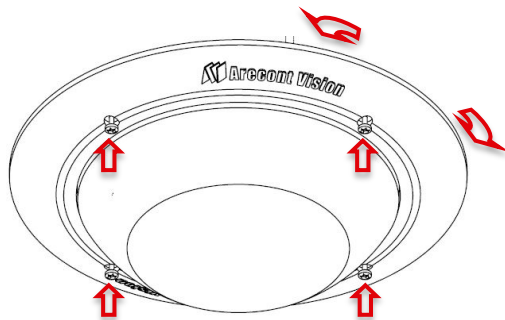

6. To configure the camera, reference the set-up section.

Pendant Mount

For a proper pendant mount installation, the AV-PMJB pendant mount and SO-CAP mount cap are required (sold separately). A pendant mount should only be attached onto hard ceilings including wood, plastic, metal, and concrete.

1. Using the mounting template, prepare the mounting provisions for the camera installation.
2. Connect top shield, pendant pole and mount together as shown in Figure 1.

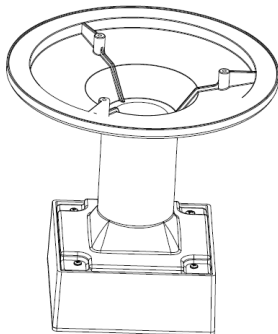

Figure 1: Attach the mount cap and pendant mount

NOTE: The thread size of top shield, pendant pole and mount is 1.5" NPT.

3. Attach the pendant mount to the ceiling using the four wood screws provided or any optional hardware suitable for the mounting surface.
4. Run the Ethernet Cable and outside power cable (if necessary) through the supplied rubber gasket and then through the pendant. Ensure the gasket is seated properly.

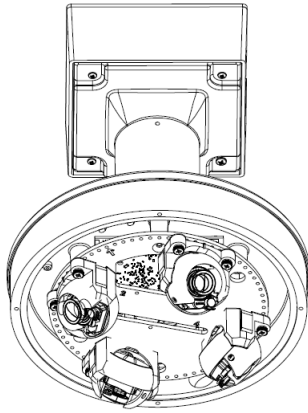

Figure 2: Attach the camera to the SO-CAP with the supplied screws

5. To configure the camera, reference the camera discovery, set-up and configuration section.

Surface Mount

The SurroundVideo® Omni G2 can be directly attached onto hard ceilings or walls including wood, plastic, metal and concrete.

1. Use the template, anchors, and screws provided to prepare the mounting provisions for the camera installation.
2. Use the supplied security L-key, to loosen the four (4) tamper resistant screws securing the dome cover. Do not remove screws from the dome cover.

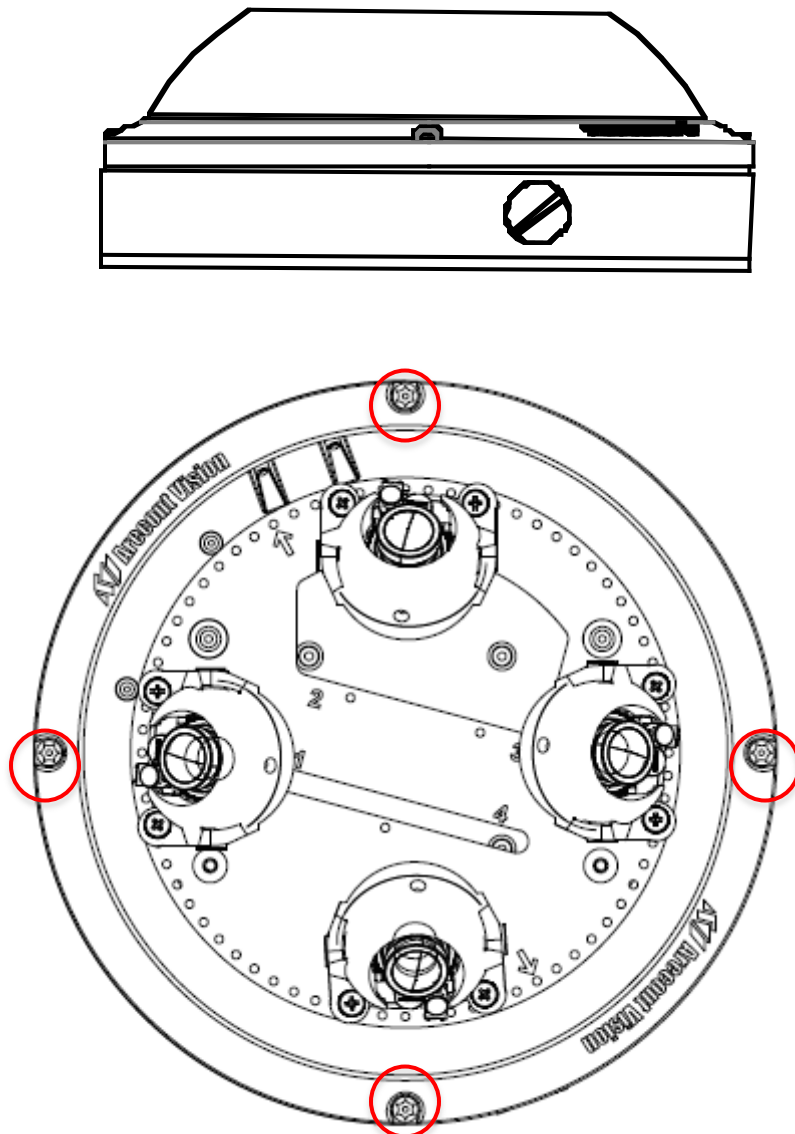

Figure 1: Remove four (4) tamper resistant screws

3. Remove the dome cover and set aside. Remove the protective foam and discard.
4. If mounting the camera outside or in a wet environment, thread the camera cable through the hole on the supplied rubber gasket and align with the three holes on the top of the housing. Ensure the gasket is properly seated flush with the camera housing.

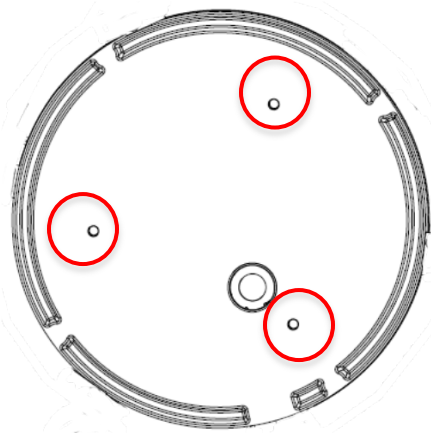
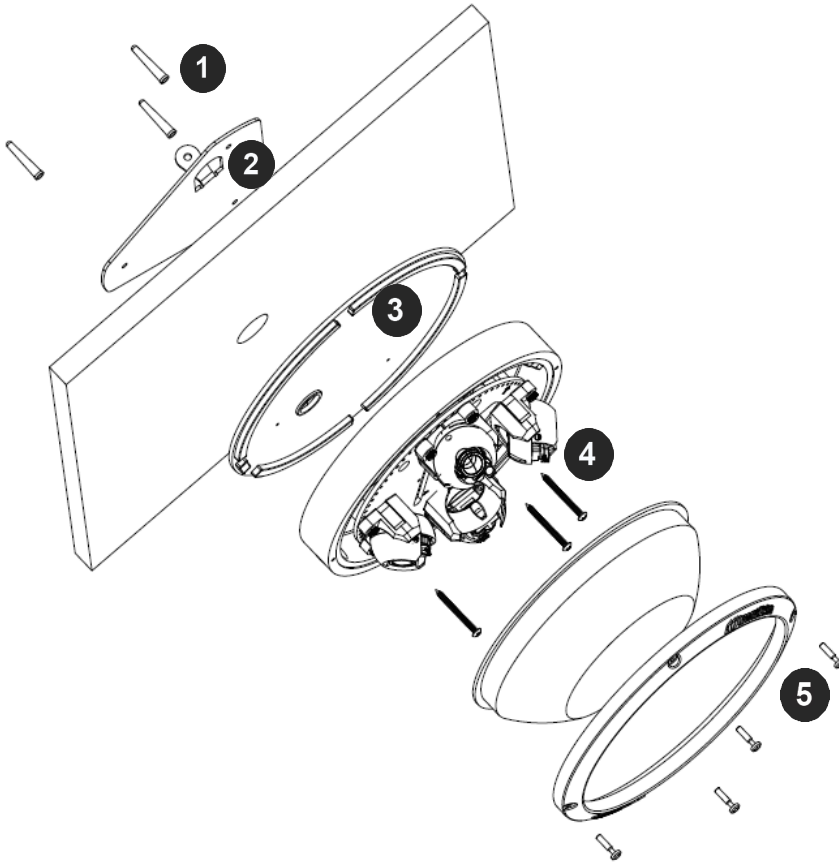

Figure 2: Mount the Surface mount to the wall or ceiling using the three holes on the housing

NOTE: If you use the side connection of the NPT port, remove the cap covering the side entrance, otherwise; leave the cap in place. If using the NPT port, always use Teflon tape around the threads to ensure proper sealing. The conduit fits $\frac{3}{4}$ " NPT standard. Ensure NPT port is facing downward.

5. Using the three holes on the top of the camera housing, use the supplied screws and attach to the mounting surface.



| Reference # | Description |
|-------------|---------------------------------------------------------------------------------------------------------------------------------------------------------|
| 1 | Install 3 supplied dry wall anchors using the supplied mounting template |
| 2 | Attach supplied (optional) tether plate |
| 3 | Attach supplied rubber gasket to the camera housing by threading the camera cable through the hole in the gasket (ensure the gasket is seated properly) |
| 4 | Align 3 supplied screws with the dry wall anchors and screw camera into place |
| 5 | Attach the dome cover, ensuring the rubber gasket is properly seated, with the tamper resistant screws |

6. Route the cable tree from the camera around the rear of the camera module and secure all cables. See the Connections section for details on how to connect the camera.
7. Check that the indicator LED's are illuminated to the desired conditions (see LED Indicator table).



CAUTION! The captive fasteners must be used to properly secure the dome cover. Failure to use the captive fastener may result in serious injury. When mounting the dome cover to the camera housing, ensure that the gasket is properly seated and not folded. Failure to do so may result in water and dust ingress. Water damage from improper installation is not covered by the warranty!

Wall Mount

For a proper wall mount installation, the AV-WMJB wall mount and SO-CAP wall mount cap are required (sold separately). A wall mount should only be attached onto hard ceilings including wood, plastic, metal, and concrete.

1. Using the Mounting template, prepare the mounting provisions for the camera installation.
2. Connect wall mount cap and wall mount as shown in Figure 1.

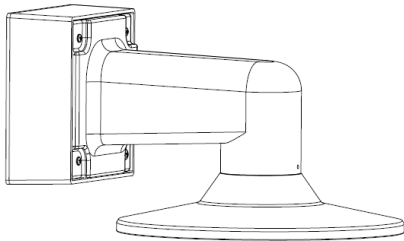

Figure 1: Attach wall mount cap to the wall mount

NOTE: The thread size for Top shield, pendant pole and mount is 1.5" NPT.

3. Run Ethernet Cable and outside power cable (if necessary) through the supplied rubber gasket and then through the wall mount. Ensure the gasket is seated properly.
4. Attach the wall mount to the wall using drywall screws or any optional hardware suitable for the mounting surface.

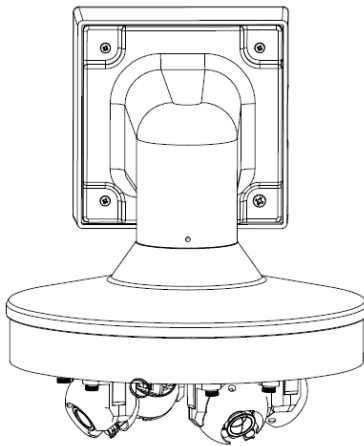

Figure 2: Attach the camera to the SO-CAP with the supplied screws

5. To configure the camera, reference the camera discovery, set-up and configuration section.

Pole Mount

For a pole mount installation, the AV-WMJB wall mount, AV-PMA pole mount, and SO-CAP mount cap are required (sold separately). A pole mount should only be attached onto hard ceilings including wood, plastic, metal, and concrete.

1. Using the mounting template, prepare the mounting provisions for the camera installation.
2. Connect the wall mount cap and wall mount.
3. Attach the AV-JBA (Junction Box Adapter) to the Pole Mount Adapter (Figure 1).
4. Remove the conduit plug on the junction box adapter and connect 3/4" NPT conduit to the junction box adapter (Figure 1).

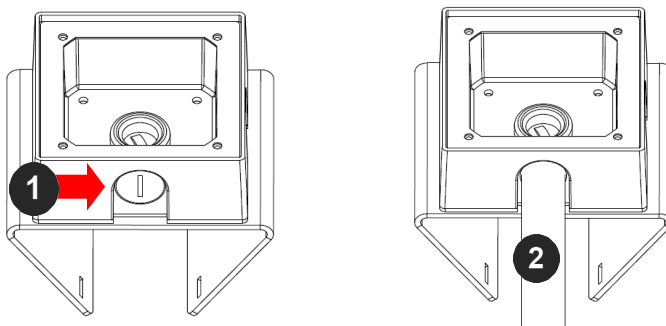

Figure 1: Attach conduit to AV-JBA junction box adapter

| Reference # | Description |
|-------------|----------------------------------------------------------------------------------|
| 1 | Remove conduit plug |
| 2 | Connect 3/4" NPT conduit to junction box adapter (ensure use of water seal tape) |

NOTE: Use silicon or water pipe seal tape to make sure no water leakage between conduit pipe and junction box adapter.

5. Run the Ethernet cable and outside power cable (if necessary) through the supplied rubber gasket and then through the Junction Box Adapter and SV-WMJB, Wall Mount Adapter. Ensure the gasket is seated properly.
6. Attach the Wall Mount Adapter (SV-WMJB) to the Pole Mount Adapter (AV-PMA) as shown in Figure 2.

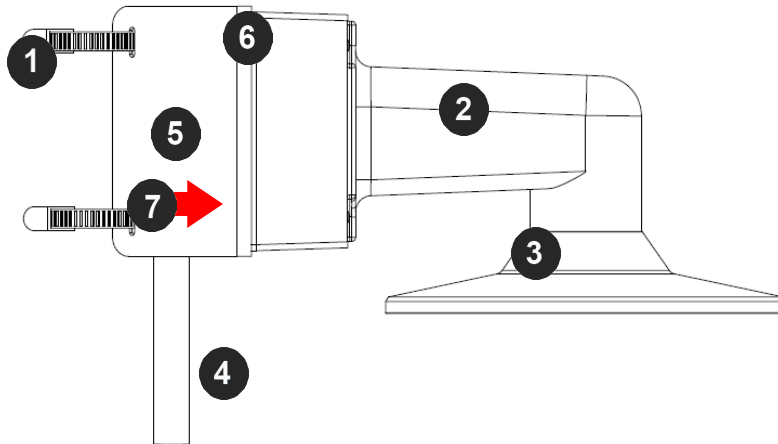

Figure 2: Attach wall mount adapter to pole mount adapter

| Reference # | Description |
|-------------|------------------------------------------------------------------------------------|
| 1 | Steel straps with compression screws |
| 2 | AV-WMJB wall mount |
| 3 | SO-CAP mount cap |
| 4 | Conduit |
| 5 | AV-PMA pole mount |
| 6 | AV-JBA Junction box |
| 7 | Apply Teflon water seal tape to the thread of 3/4" NPT pipe to avoid water leakage |

7. Use the supplied two Steel Straps to attach the Pole Mount Adapter to the pole and tighten the compression screws as shown in Figure 2.
8. Attach the camera with the in-ceiling mount to the Wall Mount Adapter.
9. To configure the camera, reference the camera discovery, set-up and configuration section.

Corner Mount

For a corner mount installation, the AV-WMJB wall mount, AV-CRMA corner mount, and SO-CAP mount cap are required (sold separately). A corner mount should only be attached onto hard corner surfaces including wood, plastic, metal, and concrete.

1. Using the Mounting template, prepare the mounting provisions for the camera installation.
2. Connect the wall mount cap and wall mount.
3. Attach the AV-JBA (Junction Box Adapter) to the Corner Mount Adapter (Figure 1).
4. Remove the conduit plug on the junction box adapter and connect 3/4" NPT conduit to the junction box adapter (Figure 1).

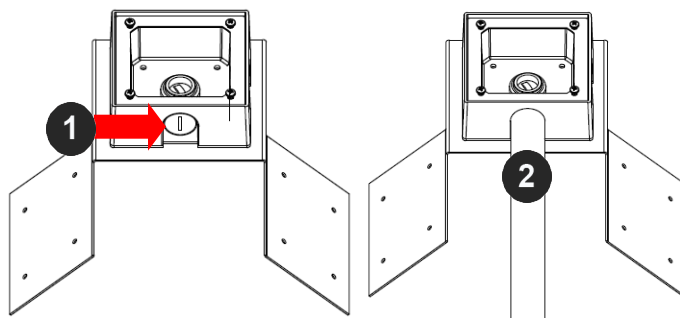

Figure 1: Attach conduit to SV-JBA junction box adapter

| Reference # | Description |
|-------------|----------------------------------------------------------------------------------|
| 1 | Remove conduit plug |
| 2 | Connect 3/4" NPT conduit to junction box adapter (ensure use of water seal tape) |

NOTE: Use silicon or water pipe seal tape to make sure no water leakage between conduit pipe and junction box adapter.

5. Run the Ethernet cable and outside power cable (if necessary) through the supplied rubber gasket and then through the Junction Box Adapter and SV-WMJB, Wall Mount Adapter. Ensure the gasket is seated properly.
6. Attach the Wall Mount Adapter (SV-WMJB) to the Corner Mount Adapter (AV-CRMA) as shown in Figure 2.

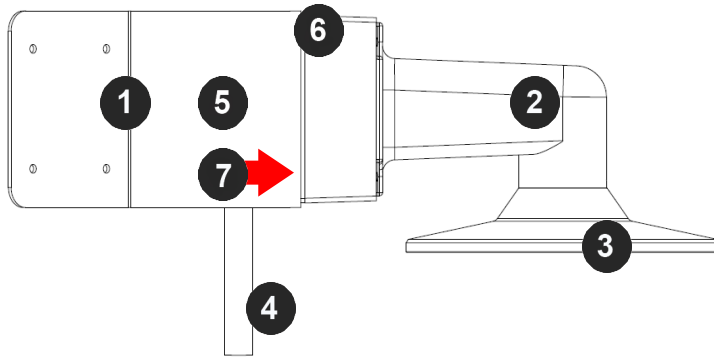

Figure 2: Attach corner mount adapter to exterior corner wall

| Reference # | Description |
|-------------|------------------------------------------------------------------------------------|
| 1 | Attach corner mount adapter to exterior 90° corner wall |
| 2 | AV-WMJB wall mount |
| 3 | SO-CAP mount cap |
| 4 | Conduit |
| 5 | AV-CRMA corner mount adapter |
| 6 | AV-JBA Junction box |
| 7 | Apply Teflon water seal tape to the thread of 3/4" NPT pipe to avoid water leakage |

7. Using the screws provided (or other hardware), attach the Corner Mount Adapter to an exterior 90° corner wall.
8. Attach camera with in-ceiling mount to Wall Mount Adapter.
9. To configure the camera, reference the camera discovery, set-up and configuration section.

Electrical Box Adapter

The AV-EBA electrical box adapter is used to attach the camera to a common single, double or square electrical box.

1. Using the AV-EBA's supplied machine screws, match the mounting holes on the adapter with the threaded holes on the electrical box. Ensure every threaded hole is matched with a mounting hole.
2. Attach the electrical box adapter to the user supplied electrical box.

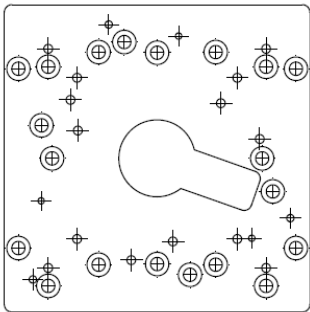

Figure 1: Attach AV-EBA adapter to common electrical box

Setting up the Cameras

The SurroundVideo® Omni is user configurable. Prior to installing the camera, thought should be given to the sensor positions. It is always easier to make adjustments before the camera is installed.

The camera lenses are shipped in a 360° position as shown below (Figure 2). To customize the sensors, simply remove the two screws for each individual sensor, position anywhere on the magnetic track and then screw into place. Screw holes around the circumference are spaced in 5 degree increments. The arrows marked on the track plate are 45 degree reference points (Figure 1).

Sensor numbering is indicated on the track plate; which corresponds to the sensor number via the camera software (Figure 1). The slots on the track plate provide additional adjustment of the camera after installation. Simply loosen the three screws to rotate the plate then tighten the three screws after alignment. This feature is most useful for repositioning the cameras mounted to the center locations after the camera installation.

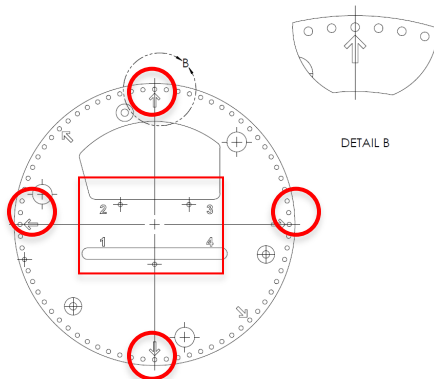

Figure 1: Arrows on the track plate indicate 45° increments

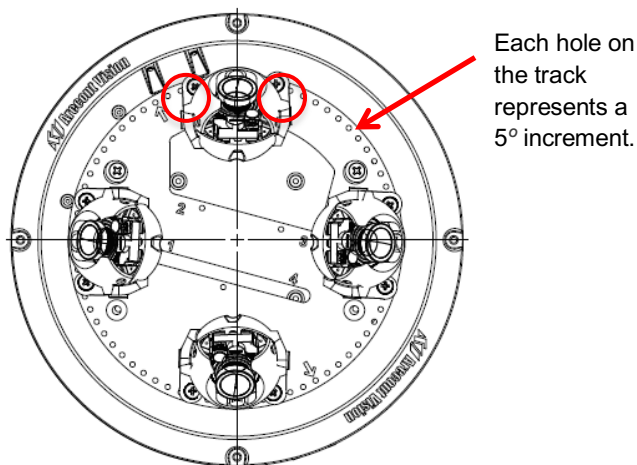
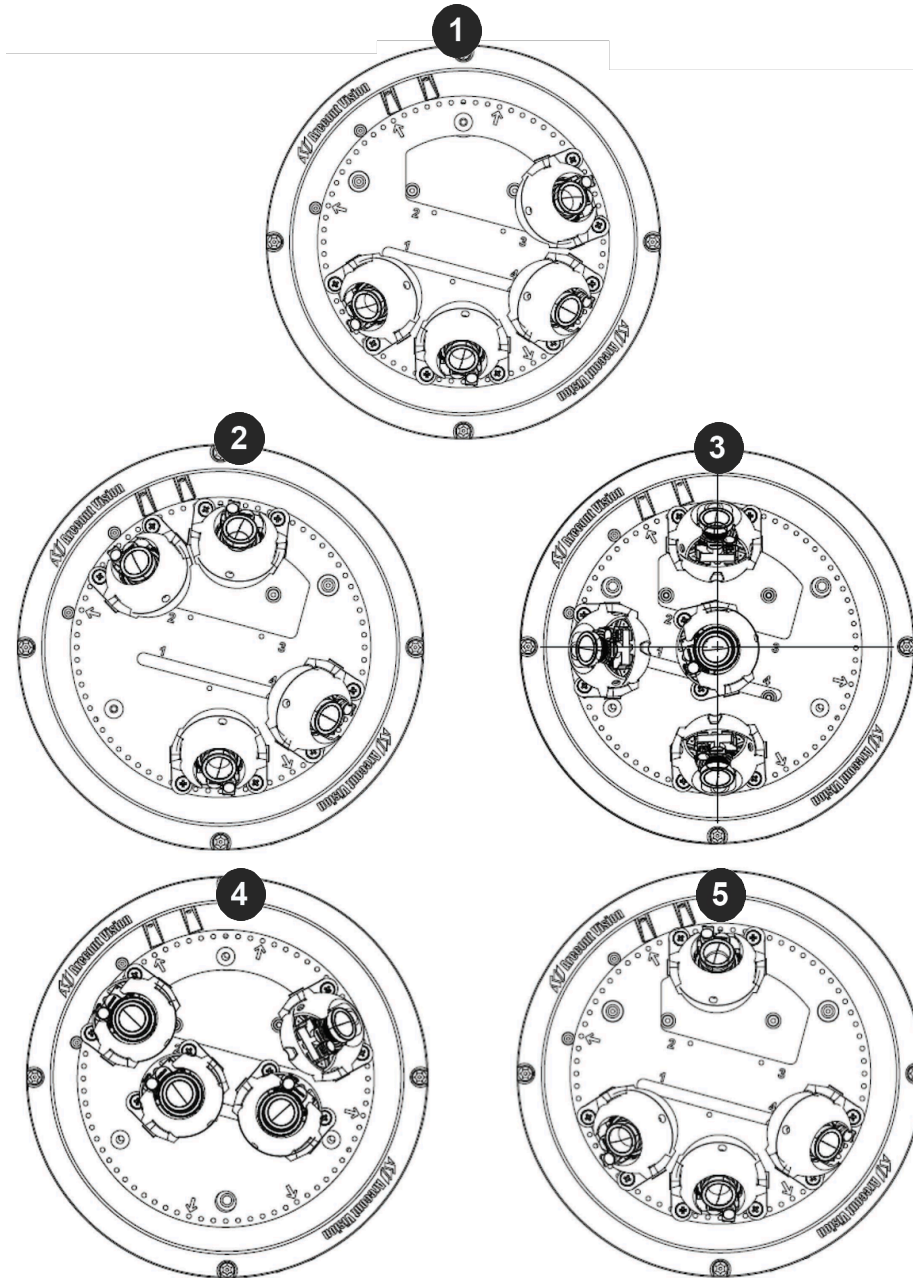

Figure 2: 360° configuration (ideal for hallways)



| Reference # | Description |
|-------------|-----------------------------|
| 1 | 180° configuration |
| 2 | Random configuration |
| 3 | 270° configuration |
| 4 | Assembly line configuration |
| 5 | Random configuration |

Aligning the Cameras

Properly aligning each camera is essential during setup. Each camera must be placed in a counterclockwise sequence on the circumference of the track to ensure proper viewing of each camera.

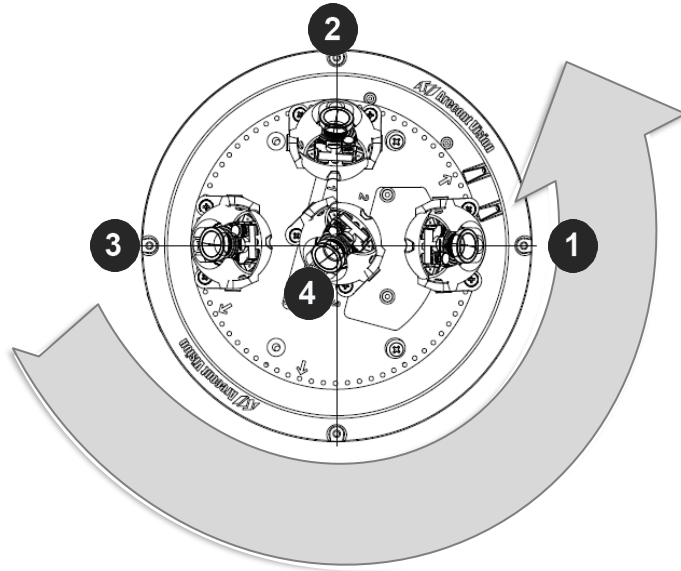
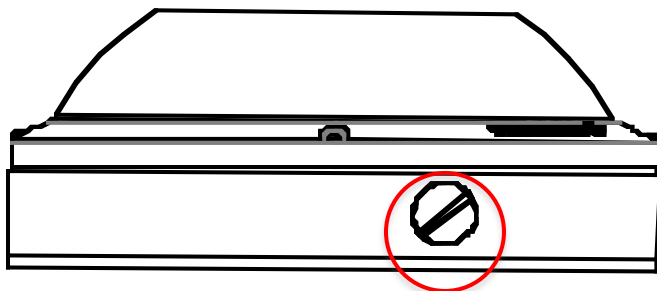

Figure 1: Place cameras in counterclockwise position on the track

| Reference # | Description |
|-------------|-------------|
| 1 | Sensor 1 |
| 2 | Sensor 2 |
| 3 | Sensor 3 |
| 4 | Sensor 4 |

When positioning the sensors, ensure the conduit mounting hole does not obstruct the cable when positioning the sensor.



Adjusting the Pan, Tilt and Focus

1. Remove the dome cover by loosening the captive fasteners with the supplied Philips head screwdriver.
2. Power on the camera to adjust the pan, tilt and focus.
3. Adjust the pan and tilt to obtain the desired field of view. Then, lock the camera head in place by tightening at least two of the three set-screws with the supplied flat-head screwdriver (Figure 1). Do not over torque the screws.

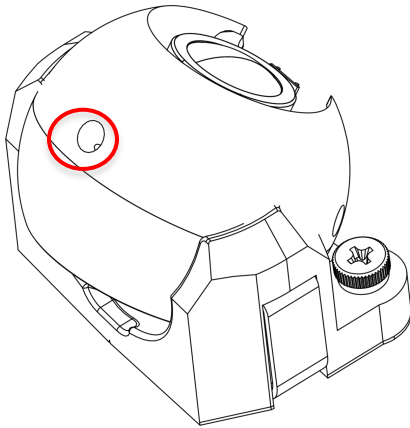

Figure 1: Lock camera head after adjusting the field of view

NOTE: Ensure not to press the remote focus motor against the sides of the camera module when adjusting the field of view (Figure 2).

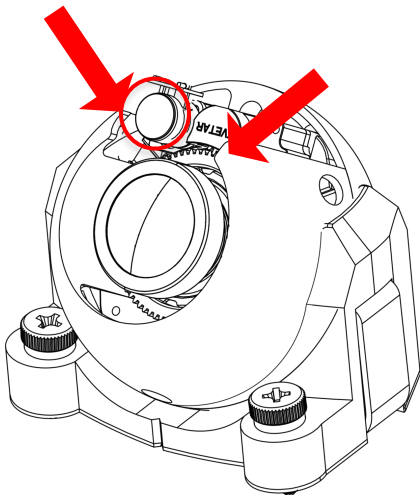
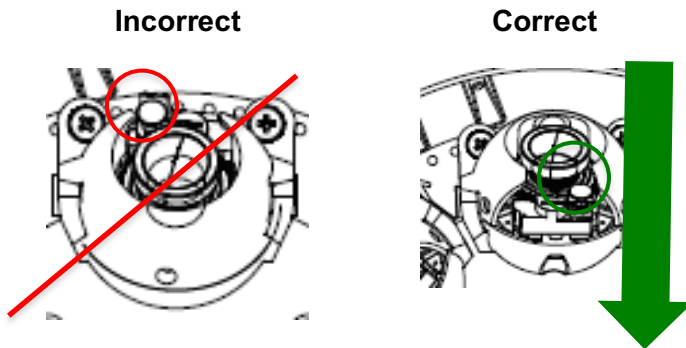

Figure 2: Remote focus motor

4. To adjust the focus, see the Remote Focus Section of this manual.

NOTE: Positioning the lens motor to close to the board may cause interference with the magnetic Omni track. Ensure each lens motor is positioned away from the board.



Changing the Lens

1. Remove the dome cover by loosening the captive fasteners with the supplied L-key.
2. Loosen the lens lock screws (3) using the supplied flat-head screwdriver (if necessary). Only do so if the lens seems very tight when turning.

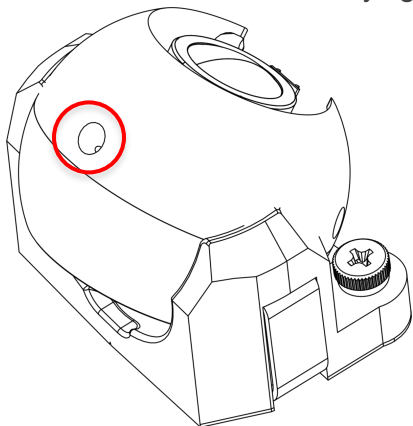

3. Manually unscrew the lens counter clockwise, this may take several seconds.

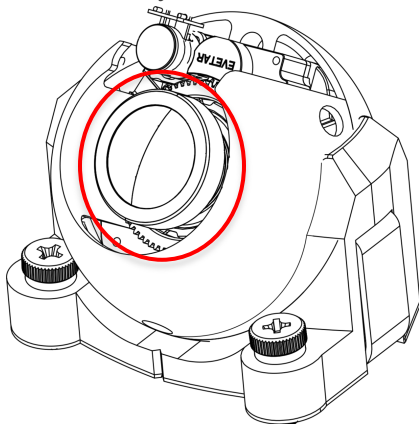

4. Screw the replacement lens clockwise until you feel some resistance and hit a hard stop.
5. Retighten the lens lock screws (3) if necessary per instructions outlined above. Do not over torque the screws.

Auxiliary I/O Functions

The auxiliary input and output are accessible from the back panel, as shown in Figure 1.

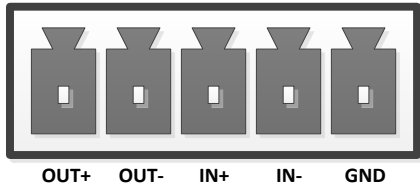

Figure 1

The output consists of an optically coupled solid state relay (SSR) and the input has an optocoupler. Both the SSR and optocoupler have an isolation voltage of 1500 VRMS between the external terminals and internal camera circuitry. The input is further protected with a serial 250Ω resistor and a debouncing circuit.

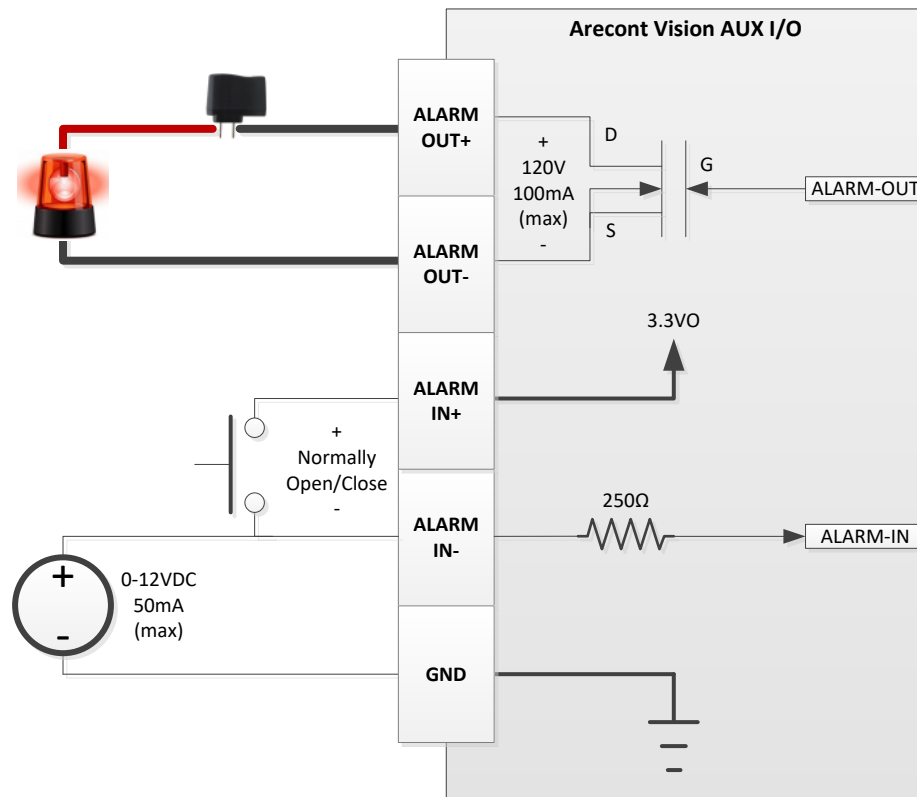

Figure 2: AUX I/O use case example

OUTPUT Relay Control and Function

The camera has an output for activating an external device. The camera supports both transient and continuous relay operation. You can operate the relay during an active connection using the API command set. Typical applications include turning on lights or activating doors and locks.

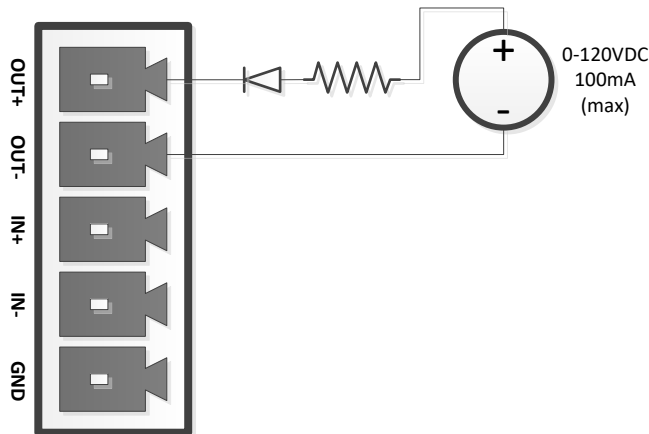

Figure 3: Relay wiring with power source to the camera

Camera output can be turned on/off with the following command:

[http://camera_ip/set?auxout=\(“on”|“off”\)](http://camera_ip/set?auxout=(“on”|“off”))

The following table shows the output control and electrical characteristics:

| Output Control | | | | |
|----------------|-----------------|---------------|-------------|-------------|
| Terminals | External Status | Camera Status | Max Voltage | Max Current |
| OUT+ & OUT- | OPEN | OFF | 120V | - |
| | CLOSED | ON | - | 100mA |

INPUT Alarm Control and Detection

The input optocoupler supports two ways to connect external unsupervised alarms to Arecont Vision camera. **Only one of the following two schemes should be used at any given time.**

OPTION-1: UNSUPERVISED ALARM DETECTION

In this scheme the IN+ & IN- terminals can be used for external signaling devices, such as door contacts or motion detectors. Both normally open and normally closed devices are supported as shown in Figure 4:

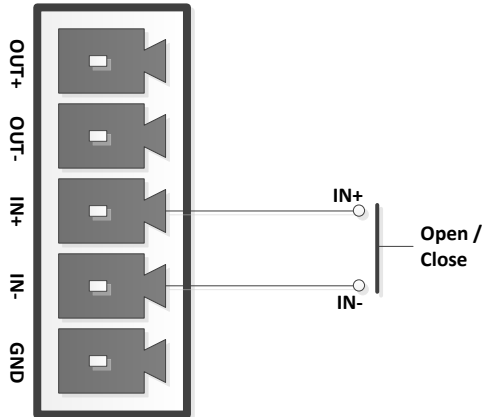

Figure 4

Figure 5 illustrates the unsupervised alarm conditions:

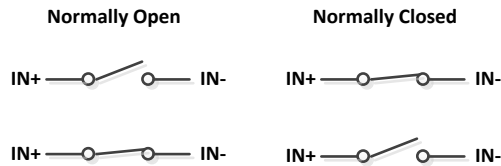

Figure 5

The following table shows how camera detects unsupervised alarms:

| Input Unsupervised Alarms | | |
|---------------------------|-----------------|---------------|
| Terminals | External Status | Camera Status |
| IN+ & IN- | OPEN | OFF |
| | CLOSE | ON |

Camera status can be read with the following command:

http://camera_ip/get?auxin

OPTION-2: INPUT VOLTAGE DETECTION

In this scheme the IN- & GND terminals can be tied to an external power source. The camera can detect a range of voltage to trigger an internal alarm on/off condition.

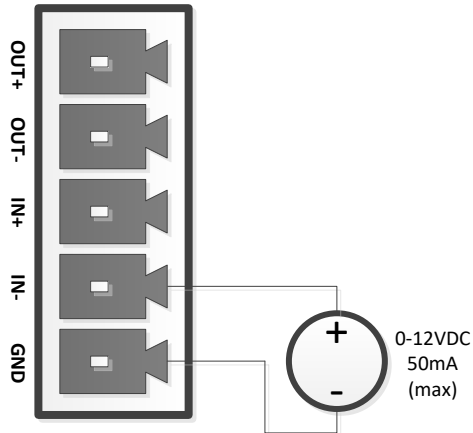

Figure 6

The following table shows the input voltage range and electrical characteristics:

| Input Voltage Detection | | | | |
|-------------------------|-----------------|---------------|---------------|---------------|
| Terminals | External Status | Camera Status | Voltage Range | Current Range |
| IN- & GND | OFF | OFF | 0-1V | 0-2mA |
| | ON | ON | 2-12V | 10-50mA |

The status of the camera can be read with the following command:

http://camera_ip/get?auxin

Camera Power Up



This product should be installed by a qualified service technician in accordance with the National Electrical Code (NEC 800 CEC Section 60) or applicable local code. Make sure that your installation of wires complies with Electrical Code of the local government where the camera is installed and no bare wires are exposed.

1. Connect the camera to a PoE port on 100Mbps network PoE switch using an Ethernet cable as shown in the image below.

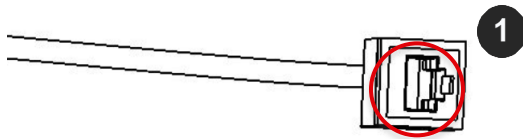

| Reference # | Description |
|-------------|---------------|
| 1 | PoE Connector |

2. If the camera is powered by an outside power supply, 18~48VDC or 24VAC, connect the power cable.

Auxiliary Power

If the camera is powered by a separate outside AC or DC power source, run the supplied power cable through the access hole on the camera housing and connect the power cable to the 4-position connector on the main camera board. The approximate location of the 4-position connector is circled below.

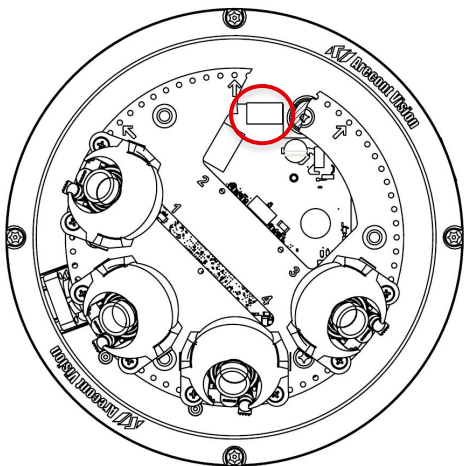



CAUTION! Make the connections inside a watertight compartment. Isolate unused power wires individually.

After connections are made, ensure that the watertight compartment is tightly closed and cables and conduits are properly sealed to prevent ingress of water.

3. Connect the PoE switch to your computer's network port using an Ethernet cable.

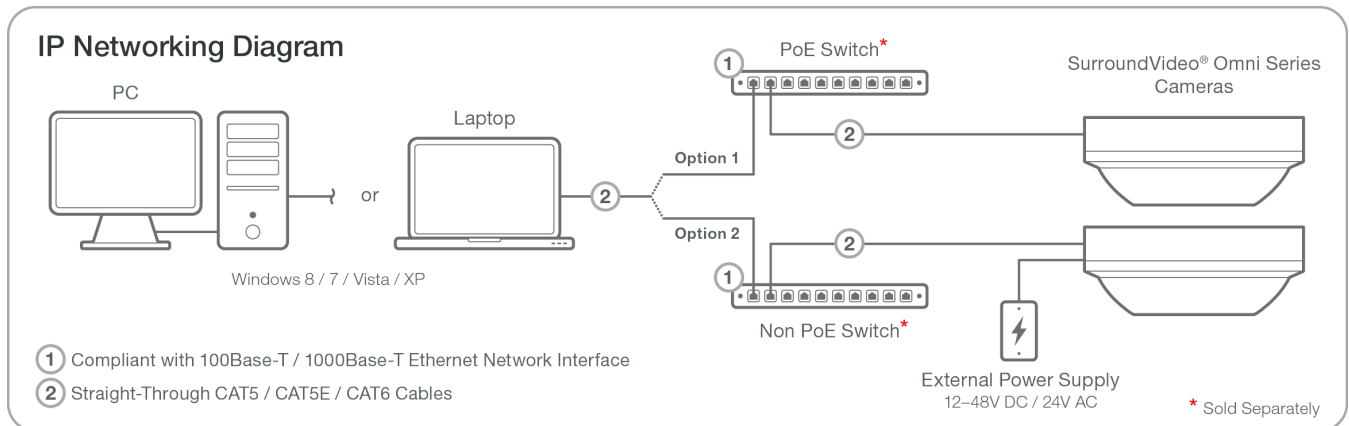

NOTE: A yellow LED on the rear of the camera illuminates after a few seconds.

- The flashing yellow LED indicates that a link to your computer has been established.
- A green LED will blink when the camera has been accessed.

| LED | Status | Description |
|--------|----------|---------------------------------------------|
| Yellow | Flashing | Link has been established. |
| | Solid | Normal Operation. |
| Green | Flashing | Camera has been accessed. Normal operation. |
| | Solid | N/A |
| None | None | No Connection. |

NOTE: Wiring methods shall be in accordance with the National Electrical Code/NFPA 70/ANSI, and with all local codes and authorities having jurisdiction. Wiring should be UL Listed and/or Recognized wire suitable for the application.

System Requirements

Computer with Windows XP/Vista/7 operating system, network access, and Microsoft Internet Explorer web browser version 9.0 or later (32-bit).

Camera Discovery, Setup, and Configuration

For camera discovery and setup, the AV IP Utility is recommended. The software can be found on the CD included with your camera or at: <http://www.arecontvision.com/software.php>.

The AV IP Utility has the ability to provide multiple discovery options, including broadcast and multicast, check the status of a camera, change camera settings, import and export camera settings via a .csv file, and update firmware and/or hardware from virtually anywhere with a network connection.

Whether used for large installations that require an update to multiple settings, or smaller installations where only one camera needs changed, the AV IP Utility tool is efficient and convenient for mass or single camera uploads.

The AV IP Utility tool is compatible with all Arecont Vision® megapixel cameras. The user manual for the software is included on the CD that came with your camera or available on our website.

Network Protocols

The Arecont Vision SurroundVideo® G5 cameras support RTSP, RTP/TCP, RTP/UDP, HTTP, DHCP, TFTP, and IP version 4 (IPv4).

Note: Concurrent multi-streaming via RTSP and TFTP is not supported.

RTSP – Cameras communicate with video management systems over Real Time Streaming Protocol. Do not change the RTSP port unless you are sure your VMS does not use the default setting.

RTP/TCP – The Real-time Protocol/Transmission Control Protocol is best suited for applications that require high reliability, and transmission time is relatively less critical.

RTP/UDP – The Real-time Protocol/User Datagram Protocol is used for live unicast video, especially when it is important to always have an up-to-date video stream, even if some images are dropped.

HTTP – The Hypertext Transfer Protocol is an application protocol for distributed, collaborative, hypermedia information systems.

DHCP – The Dynamic Host Configuration Protocol allows network administrators to centrally manage and automate the assignment of IP addresses. DHCP should only be enabled if using dynamic IP address notification, or if the DHCP can update a DNS server.

TFTP – The Trivial File Transfer Protocol is a simple, lock-step, File Transfer Protocol which allows a client to get from or put a file onto a remote host. TFTP lacks security and most of the advanced features offered by more robust file transfer protocols such as File Transfer Protocol.

QoS – Quality of Service guarantees a certain level of a specified resource to selected traffic on a network. A QoS-aware network prioritizes network traffic and provides a greater network reliability by controlling the amount of bandwidth an application may use.

IPv4 – This camera supports the IPv4 internet-layer protocol for packet-switched internetworking across multiple IP networks. IPv4 uses 32-bit addressing which allows for devices and users on the internet for routing traffic.

General Remote Focus

1. To control the remote focus via the web interface, double click the camera within the AV IP Utility (Figure 1) or open your preferred web browser and type the camera's IP address (Figure 2).

NOTE: For supporting H.264 streaming on a webpage, the recommended browsers are Internet Explorer and Firefox.

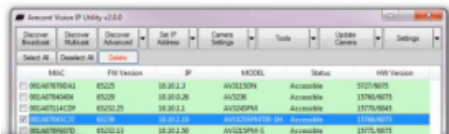

Figure 1: Double click via AV IP Utility

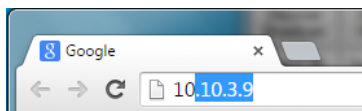

Figure 2: Type the camera IP address

2. Scroll to the Focus Tab section.



NOTE: Additional information regarding the Arecont Vision® web interface is found separately in the **AV IP Utility Web Browser Manual** via the Arecont Vision website.

3. Click the “Select Channel” and choose channel 1.
4. Click the Full-range Focus button. The camera begins to autofocus with the lens stopping at the best overall point of focus.



5. Please complete the same action for Channel 2, 3, and 4 by following steps 2 to 5.

AV IP Utility Focus Tab

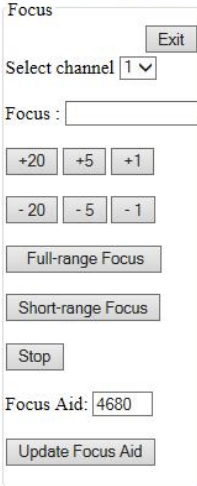
| Menu | Feature | Description |
|-----------------------------------------------------------------------------------|----------------------------------------|-----------------------------------------------------------------------------------------------------------------------------------------------------|
|  | Select Channel | Allows user to change settings of each channel. All the parameter settings in “Settings” Menu only apply to the selected channel. |
| | Manual Focus: +20, +5, +1, -20, -5, -1 | Numbers indicate the level of focusing in order to adjust the field-of-view. |
| | Full-range Focus | Best for scenes that are completely out of focus. The camera automatically scans the full focus range of the scene to find the best focus position. |
| | Short-range Focus | Best for scenes that are slightly of out of focus. The camera quickly fine-tunes for a precise focus position. |
| | Stop | Stops any command in progress. |
| | Focus Aid | The higher the focus aid value means the more the lens is required to focus. |
| | Focus Aid: 4680 | |

Troubleshooting

Before troubleshooting, visit <http://www.arecontvision.com/> to ensure your camera has the most current firmware version.

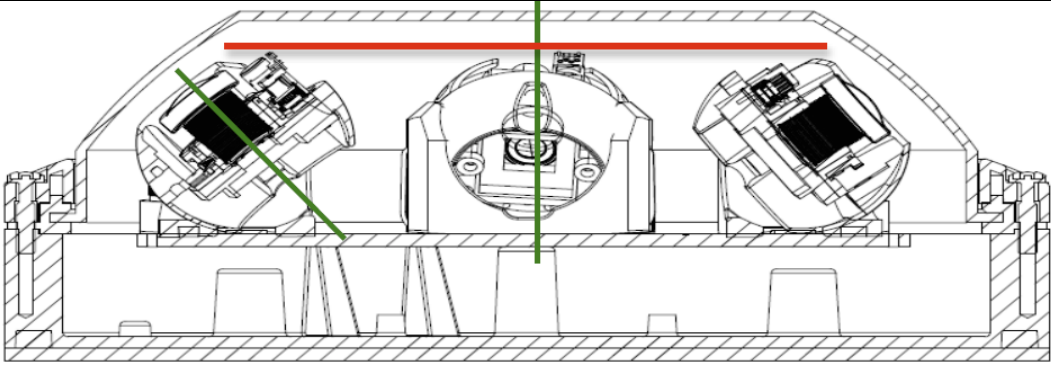
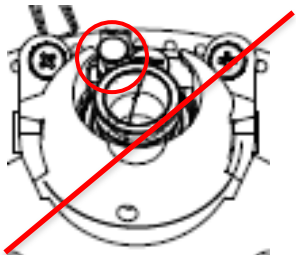
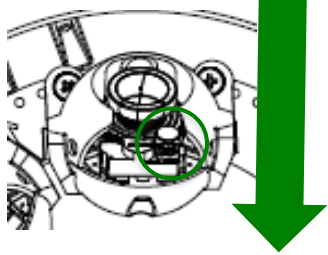
| Problem | Possible Cause | Solution |
|-------------------------------------------------------------------------------------|--------------------------------------------------------------------------------------------------------------------------------------------------------------------|----------------------------------------------------------------------------------------------------------------------------------------------------------------------------------------------------------------------------------------------|
| Reflection on the image | <ul style="list-style-type: none"> • Lens faces the bubble's crease. • The angle between the lens and bubble are not perpendicular. | <ul style="list-style-type: none"> • Ensure the lens faces the bubble perpendicularly. • Avoid facing the lens at the bubble's crease. • Ensure each lens is tilted up 90° when facing down as shown below. |
|  | | |
| Day/Night switch failure or image quality problem | <p>The lens motor positioned to close to the board may cause interference.</p>  | <p>Ensure each lens motor is positioned away from the board.</p>  |

SurroundVideo Omni Mounting Template

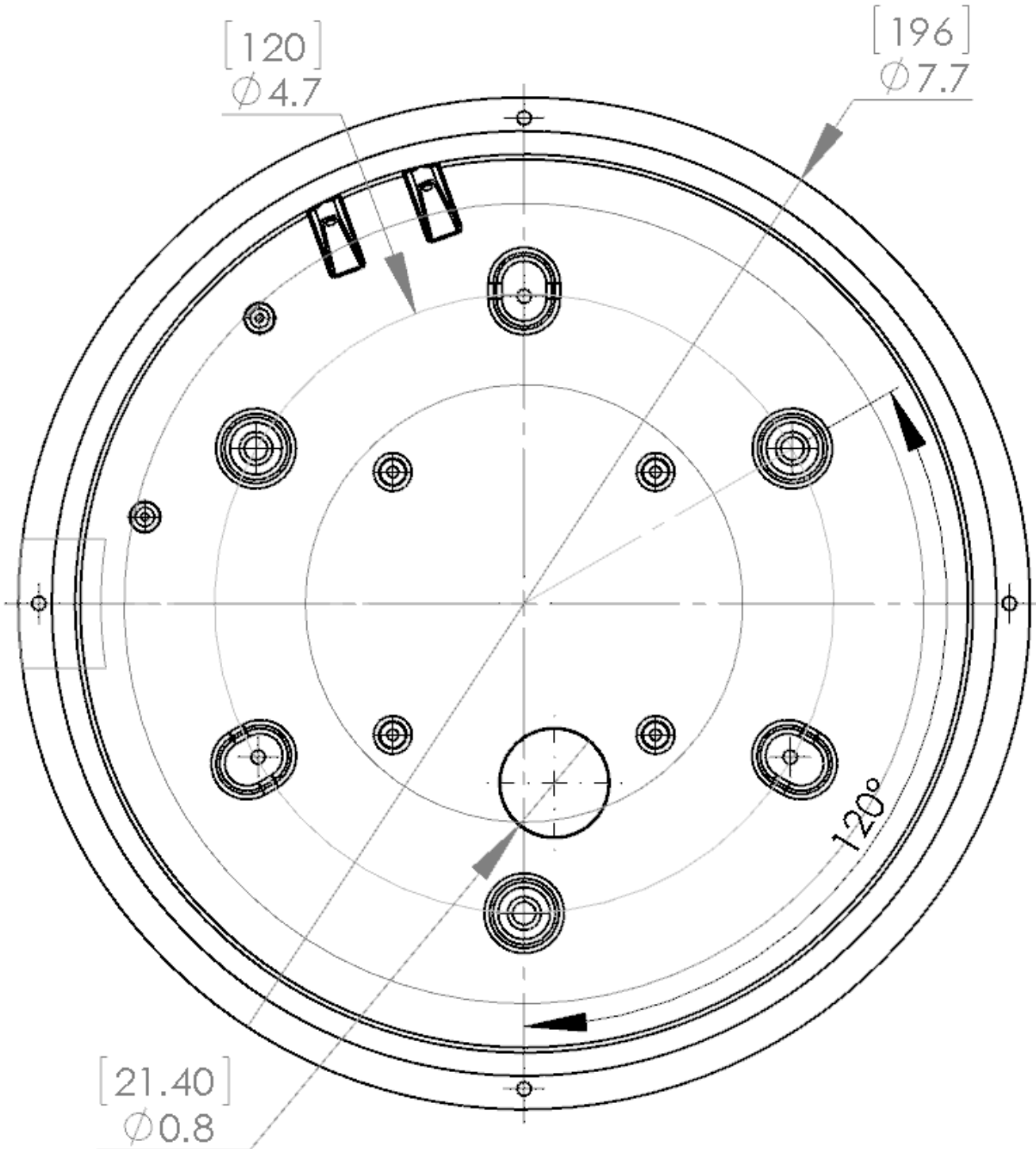

Support

1. Arecont Vision FAQ Page Located at ArecontVision.com
2. Check the following before you call:
 - Restore camera to factory default with AV200 or the camera webpage.
 - Upgrade to the latest firmware by visiting ArecontVision.com.
 - Isolate the camera on a dedicated network and test with AV200.
 - Swap the “troubled” camera with a known good camera to see if the problem follows the camera or stays at the location.
3. Contact Arecont Vision Technical Support one of three ways:
 1. Online Portal: Support.ArecontVision.com
 2. Phone: 1.818.937.0700 (option #1)
 3. Email: support@arecontvision.com